

Sapphire[®]

Sapphire Liquid Fuel Modulating Boiler Balanced Stainless Steel Flue and Plume Kit Options



CE UK UK
NI CA



EOGB 
Reliable energy. Flexible approach.

		Page
1	Information & General Warnings	
1.1	Introduction	1
1.2	Symbols used in the manual	1
1.3	Safety Precautions	1
1.4	Appliance Operation	1
1.5	Health and Safety	1
1.6	Combustion and Corrosive materials	1
1.7	Fitting and Modification	1
1.8	Servicing	2
1.9	Installation Regulations	2
1.10	Complying with the Building Regulations	2
2	Low Level Horizontal Balanced Stainless Steel STANDARD Flue Options (Rear/Side Exit)	
2.0	EOGB Sapphire Low Level Horizontal SIDE/REAR Stainless Steel Balanced Flue System Kits	3
2.1	Short and Long Adjustable Low Level STANDARD Terminal Dimensions (Side and Rear)	3
2.2	STANDARD Low Level Short Terminal Kit Dimensions	3
2.3	STANDARD Low Level Long Terminal Kit Dimensions	3
2.3.1	Extended Rear Section for Low Level Long Terminals Dimensions	3
2.4	MINIMUM CLEARANCES AND PROJECTIONS for Short and Long Adjustable Low Level STANDARD Terminals (Side and Rear)	4
2.5	Side or Rear Location Options	4
2.6	Drilling the Low level Flue Termination hole	4
2.7	Fitting the Low Level Flue Terminal	4
2.8	Short and Long Adjustable Low Level Terminals Part Numbers	5
2.9	Noise Reducing Flue Cone	5
3	Plume Kit Options (Low Level)	
3.0	Plume Kit Extras for Low Level Horizontal SIDE/REAR Flue Kits	6
3.1	Installation of Low level PLUME KIT	7
3.2	Plume Kit Part Numbers	8
4	High Level Balanced Stainless Steel Flue Options (Internal)	
4.0	EOGB Sapphire High Level Stainless Steel Balanced Flue System Kits	9
4.1	High Level Stainless Steel Balanced Flue System Kit Configuration & Dimensions	9
4.2	High Level Type Short & Long kit (REAR Exit) Dimensions	10
4.3	MINIMUM CLEARANCES AND PROJECTIONS for High level Type Terminals (Rear)	10
4.4	High Level Type Short & Long Kit (SIDE Exit) Dimensions	11
4.5	MINIMUM CLEARANCES AND PROJECTIONS for High level Type Terminals (Side)	11
4.6	High Level Offset Flue Options/Dimensions	12
4.7	Top Exit Boiler Adaptor	12
4.8	Drilling the High Level Flue Termination Hole	12
4.9	Fitting the High Level Flue Terminal	13
4.10	Short and Long Adjustable High Level Kits & Part Numbers	13/14
5	Vertical Balanced Stainless Steel Flue Options (Internal)	
5.0	EOGB Sapphire Vertical Stainless Steel Balanced Flue System Kits & Dimensions	15
5.1	Vertical Offset Flue Options/Dimensions	16
5.2	Drilling the Flue Termination Hole	16
5.3	Top Exit Boiler Adaptor	16
5.4	Fitting the Vertical Flue Terminal	16
5.5	Vertical Balanced Flue Kits & Part numbers	17/18
5.6	Noise Reducing Flue Cone	18
6	Balanced Flue Installation	
6.0	Balanced Flue Terminal Location Installation Guidance	19





1.1 Introduction

The instruction manual supplied with the Flue Kit:

- is an integral and essential part of the product and must not be separated from the appliance. It must therefore be kept carefully for any necessary consultation and must accompany the appliance even if it is transferred to another owner or user, or to another system. If the manual is lost or damaged, another copy can be requested from EOGB on request.
- is designed for use by qualified personnel.
- offers important indications and instructions relating to the installation safety, start-up, use and maintenance of the appliance.

1.2 Symbols used in the manual

In some parts of the manual you will see danger triangular signs. Pay great attention to these, as they indicate a situation of potential danger.

The dangers can be of 4 levels, as indicated below.



This symbol indicates operations which, if not carried out correctly, cause serious injury, death or long-term health risks.



This symbol indicates operations which, if not carried out correctly, may cause serious injury, death or long-term health risks.



This symbol indicates operations which, if not carried out correctly, may cause damage to the machine and/or injury to people.



This symbol indicates operations which, if not carried out correctly, lead to electric shocks with lethal consequences.

1.3 Safety Precautions

IN THE EVENT OF ANY OIL SMELLS, LEAKS OR FUMES FROM THE APPLIANCE:

- Put out naked flames
- Open doors and windows
- Isolate the electrical supply
- Isolated the fuel supply
- Rectify the fault

1.4 Appliance Operation

This appliance must only be operated by a responsible person who has been instructed in, understands, and is aware of the appliance operating conditions and effects.

1.5 Health and Safety

The appliance contains no asbestos and no substances have been used in the construction process that contravene the COSHH Regulations (Control of Substances Hazardous to Health Regulations 1988).

1.6 Combustion and Corrosive Materials

Do not store or use any combustible materials (paper, thinners, paints etc.) inside or within the vicinity of the appliance. The combustion air must be free from chemically aggressive substances which can corrode the appliance and invalidate any warranty.

1.7 Fitting and Modifications

Flue systems must not be modified in any way other than as described in the fitting instructions. Any misuse or unauthorised modifications to the appliance, flue or associated components and systems could invalidate the warranty. The manufacturer accepts no liability arising from any such actions, excluding statutory rights.

1.8 Servicing

Advise the user to have the system regularly serviced by a competent, qualified engineer (such as OFTEC registered personnel) using approved spares, to help maintain the economy, safety and reliability of the appliance.



IMPORTANT - The service engineer must complete a Service Record after each service.

1.9 Installation Regulations

Failure to install appliances correctly could lead to prosecution.

1.10 Complying with the Building Regulations

The boiler and flue form part of the controlled services for the building. It is law that all controlled services for buildings must comply with building regulations. You must be able to satisfy your Local Authority Building Control Body (LABC) that the work carried out concerning the installation and commissioning of the heating appliances has been carried out to a satisfactory standard. OFTEC operate a competent persons scheme and registered installers are able to certify that their work complies with building regulations.

Under the scheme:

- OFTEC must be informed about every installation.
- OFTEC will issue a building regulations compliance certificate to the householder and will notify LABC.

OFTEC provide controlled document forms CD10 and CD11 for use during installation and commissioning respectively.

Other organisations operate self-certification schemes e.g. NAPIT and BESCA Ltd. and it may be possible for installers who are members of these organisations to self certify their work.

Alternatively you must submit a building control notice to the LABC before installing any boiler.

The LABC will then arrange regular inspection visits during the work to ensure that the installation complies with the regulations.

The appliance must be installed by a competent person. The person installing the appliance should be aware of the Health and Safety at Work Act and take appropriate action to ensure that the regulations are adhered to. In order to give optimum efficiency and trouble free operation the appliance must be commissioned by a qualified OFTEC engineer. The compliance with a British Standard does not, in itself, confer immunity from legal obligations. In particular the installation of this appliance must be in accordance with the relevant requirements of the following British Standards and regulations in respect of the safe installation of equipment.

BS 5410: part 1: Code of practice for Oil Fired Boilers. The Building Regulations Part J and L1 England and Wales; Part F and Part J Section III Scotland; Part L and Part F Northern Ireland. Local water company bye-laws. The Control of Pollution (Oil) Regulations. OFTEC Standards. Where no specific instruction is given, reference should be made to the relevant codes of practice be carried out by a competent engineer in accordance with these instructions and the relevant Installation Regulations.

Low Level Horizontal Balanced STANDARD Flue Options (Rear/Side Exit)

2.0 EOGB Sapphire Low Level Horizontal SIDE/REAR Stainless Steel Balanced Flue System Kits

The EOGB Sapphire low level balanced flue range has been developed to make the installation of the Sapphire Boilers as both quick and simple.

The Sapphire low level flue kits feature self-sealing ducts requiring no silicone or tape for joints, and the unique quick-fit connection arrangement ensures a perfect seal every time. The kits are compatible with all Sapphire boilers and are available with Terminals in either a black painted finish or stainless steel (which can be painted after installation to fit to the homeowners decor.)

Both STANDARD TERMINAL options are available in both **Short** and **Long** versions



IMPORTANT - Please note that EOGB Low Level Terminals are NOT compatible with High Level Terminals options and vice versa

2.1 Short and Long Adjustable Low Level STANDARD Terminal Dimensions (Side and Rear)

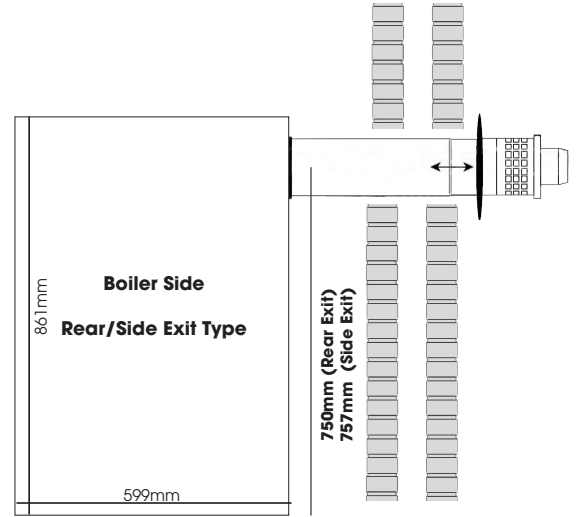
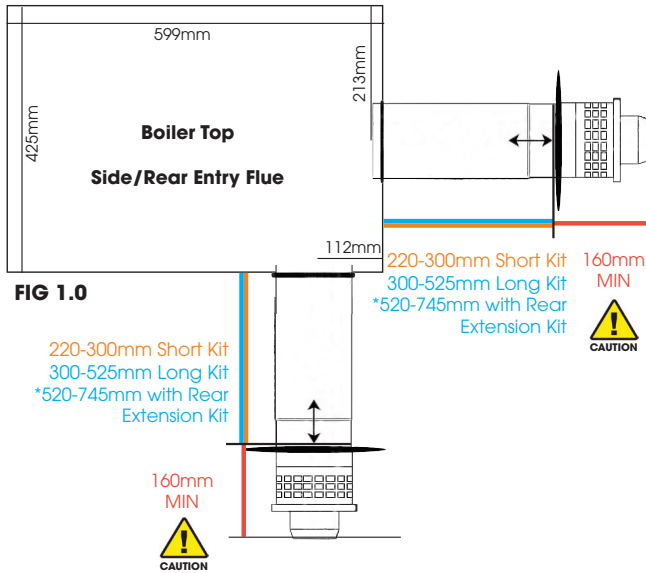

2.2 STANDARD Low Level Short Terminal Kit Dimensions

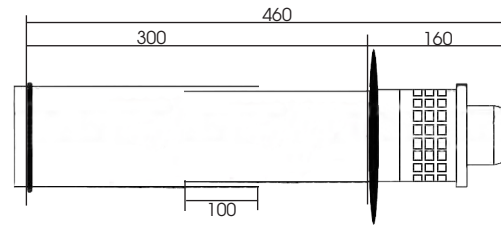
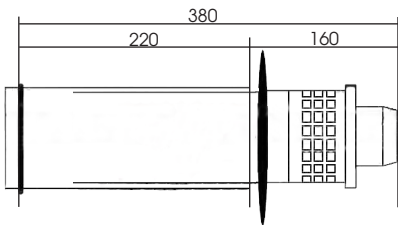

FIG 2.0

2.3 STANDARD Low Level Long Terminal Kit Dimensions

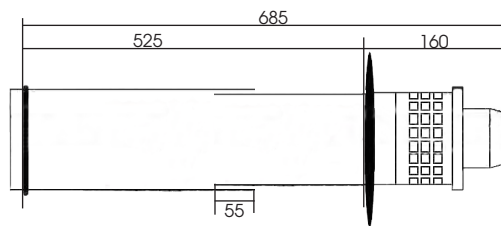
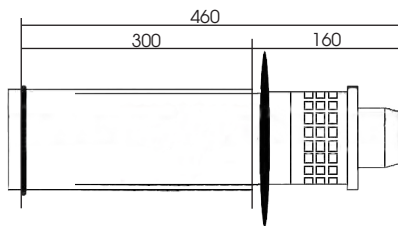

FIG 3.0

2.3.1 EXTENDED REAR SECTION for Low Level Long Terminals Dimensions *

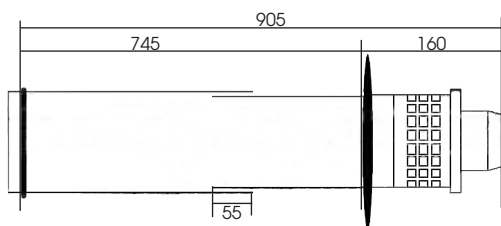
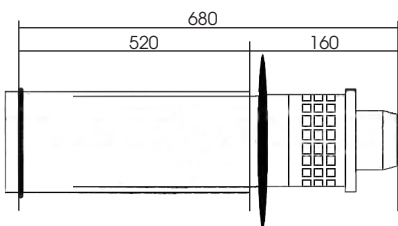

FIG 3.1

*Please note that the EXTENDED REAR SECTION kit that provides additional length to the Low Level Long flues is only suitable for the Low Level Long options and is sold as a rear section only. A Standard Low Level Long kit would need to be purchased along side this extension kit

2.4 MINIMUM CLEARANCES AND PROJECTIONS for Short and Long Adjustable Low Level STANDARD Terminals (Side and Rear)



Short and Long Adjustable Standard Low Level Terminal Minimum Clearances

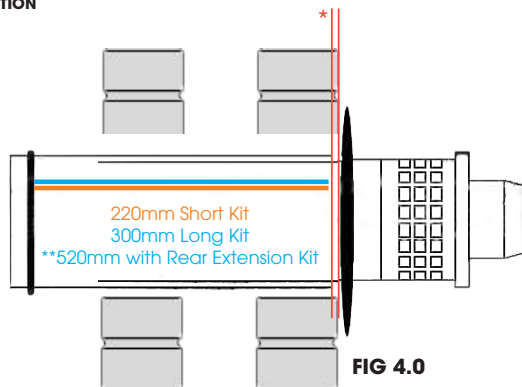

FIG 4.0



Short and Long Adjustable Standard Low Level Minimum/Maximum Terminal Projection

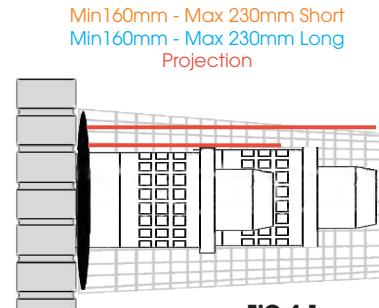

FIG 4.1



• The fixed section of the terminal **MUST** be located within the wall cavity to prevent rain water from entering and allowing the external flashing to seal.

**Please note that the EXTENDED REAR SECTION kit that provides additional length to the Low Level Long flues is only suitable for the Low Level Long options and is sold as a rear section only. A Standard Low Level Long kit would need to be purchased along side this extension kit.

2.5 Side or Rear Location Options

Once the boiler exit type has been decided (Side or Rear), Please ensure the Boiler Air intake Adaptor (supplied with the boiler) has been fitted to the correct exit type required and the appropriate casing knock out has been removed - (please refer to the Sapphire Boiler Installation Manual for more information.)

2.6 Drilling the Low Level Flue Termination Hole

Ensure the correct measurements for the flue terminal exit hole have been measured (see Table 1.0) and are in accordance with BS5410 Part 1 or 2 and Approved Document J

Drill out using a core cutter or other suitable cutting tool, the correct flue terminal hole size (See Table 1.0)

Once the flue terminal exit hole has been made, ensure that the hole and the cavity are free of any debris or potential falling debris.

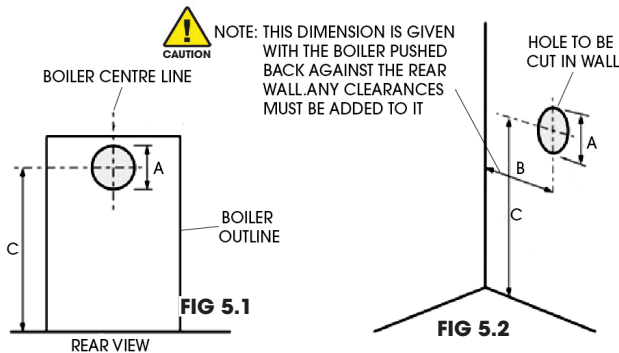

Low level side and rear exit balanced flue dimensions					
Boiler Model	Dimensions (mm)				
	A (dia)	B (Rear Exit)	B (Side Exit)	C (Rear Exit)	C (Side Exit)
Sapphire 23 - 32	127	213	112	750	757

Table 1.0

2.7 Fitting the Low Level Flue Terminal

Carefully insert the two sections of the Low Level Adjustable Terminal together taking caution not to damage the seals. (ensure that any flue seals have been lubricated using the lubrications sachets provided)

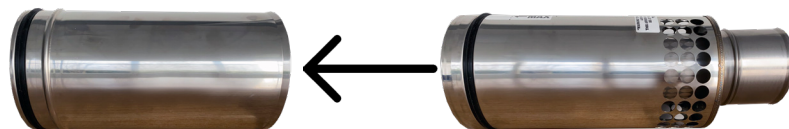

Insert the Low Level Adjustable Terminal through the flue terminal exit hole in the wall. Carefully line up and insert the terminal into the Boiler Air intake Adaptor.

Once the terminal is fitted to the boiler, adjust the adjustable terminal to the desired length ensuring that the minimum terminal projections are adhered to (see section "MINIMUM CLEARANCES AND PROJECTIONS for Short and Long Adjustable Low Level STANDARD Terminals (Side and Rear)") in section 2.4

Once set, ensure that the internal and external wall flashing plates are fitted and the terminal is adequately sealed/cemented in place.



If the terminal is located below 2 meters, ensure that the Terminal Cage Guard is fitted.

Low Level Horizontal Balanced STANDARD Flue Options (Rear/Side Exit)

2.8 Short and Long Adjustable Low Level Kit Part Numbers

Item	Description	Part number
	SHORT Adjustable STANDARD Terminal Kit (Adjustable Length 220-300mm) Includes both Internal/External Terminal Flashing Plates and Cage	Stainless Steel Terminal - SS-FLUEKITLLS-SS-01
		Stainless Steel with Black Terminal - SS-FLUEKITLLS-BK-01
	LONG Adjustable STANDARD Terminal Kit (Adjustable Length 300-525 mm) Includes both Internal/External Terminal Flashing Plates and Cage	Stainless Steel Terminal - SS-FLUEKITLLL-SS-01
		Stainless Steel with Black Terminal - SS-FLUEKITLLL-BK-01
	Low Level Rear Extension Only (Provides an adjustable length of 520-745mm when fitted with Low level LONG Terminal Kit) Note - A Standard Low Level Long kit would need to be purchased along side this extension kit	Stainless Steel - SS-FLUE225-SS-01
	Internal Flashing Plate	Stainless Steel Only - SS-FLUE218-SS-01
	External Flashing Plate	Stainless Steel - SS-FLUE220-SS-01 Black - SS-FLUE219-BK-01
	Terminal Cage Guard	Stainless Steel Only - SS-FLUE214-SS-01
	LL/HL Flue noise reducing cone kit (incs 4 x screws)	SS-ACCESS-023-01

Table 2.0

2.9 Noise Reducing Flue Cone

EOGB fit a flue noise reducing cone to the end of all flue terminals including Plume kits. This noise reducing cone helps dampen the noises caused through the combustion process. The cone is secured by 4 fixing screws and can be retrofitted.



3.0 Plume Kit Extras for Low Level Horizontal SIDE/REAR Flue Kits

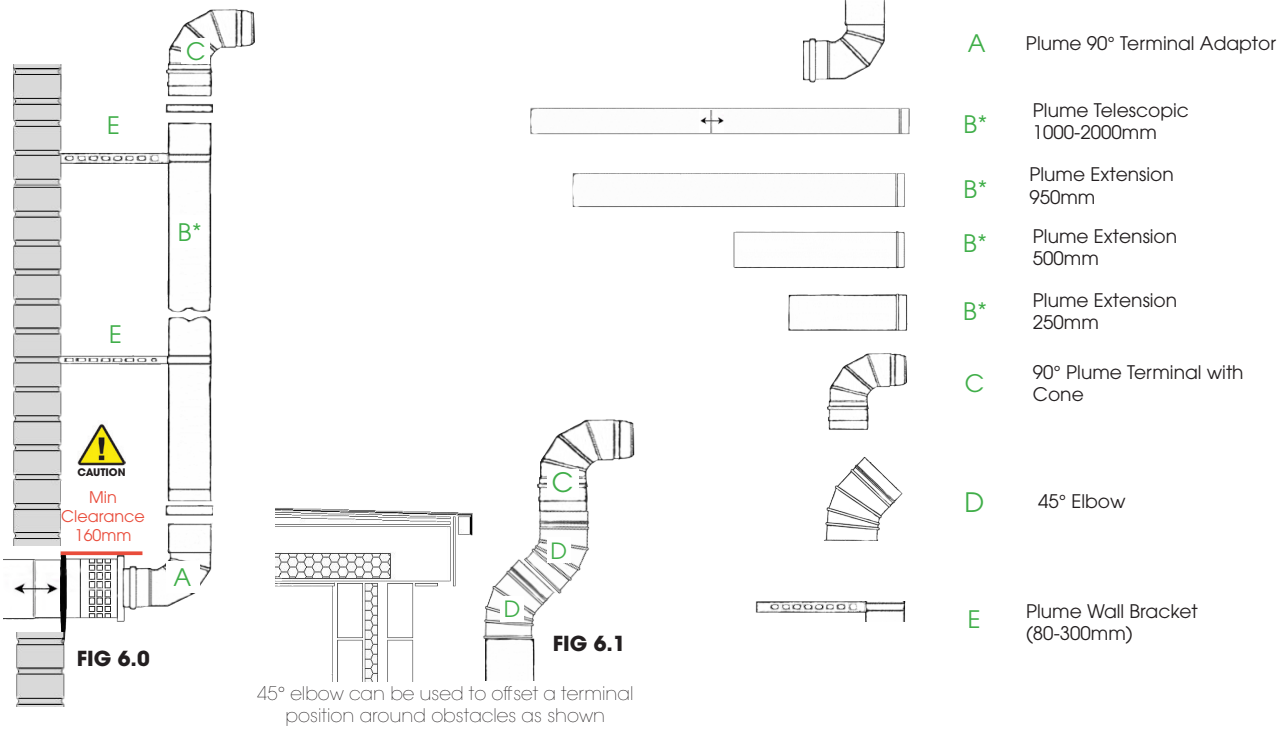

EOGBs Flexible Plume Kit options allows for plume runs to be extended by using additional extensions sections and offset 45° elbows to give much more flexibility when fitting a plume kit.

A maximum total height of 6 metres' is allowed. However, please deduct 500mm for each additional 45° elbow used.

The following illustrations provides examples of permitted plume terminal options.



Under no circumstance should a 45° degree bend be used as a plume terminal on a vertical installation. (See **FIGS 7.5**)

Under no circumstance should a 90° or 45° degree bend be used as a terminal in an upwards or downwards direction. (See **FIGS 7.6 to 7.9**)

This is to reduce the risk in the event that the boilers condensate pump is not working so to prevent the boiler being filled up with a deluge of rainwater.

Failure to follow this advice may void the manufactures warranty

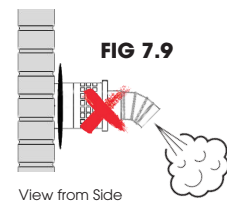
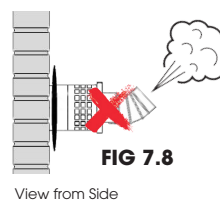
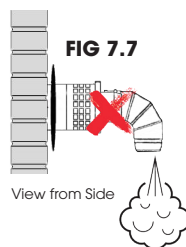
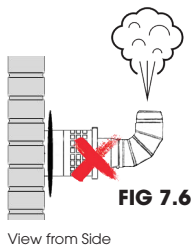
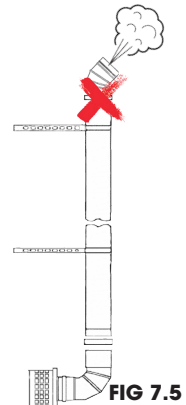
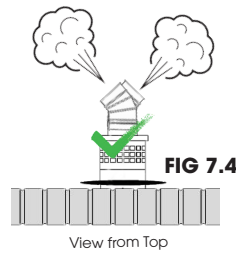
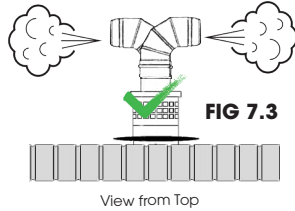
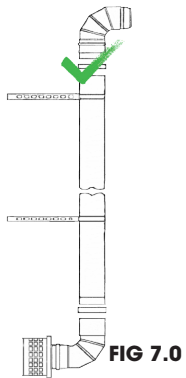

3.1 Installation of Low level PLUME KIT



Before fitting any plume sections, ensure that all flue seals have been lubricated using the lubrication sachets provided.

Ensure that the flue noise reducing cone that may be fitted to the Low / High Level Terminal is removed and discarded first! Then push the Plume 90° Terminal Adaptor into the Low Level Adjustable Terminal and ensure that the Minimum 160mm Clearance of the Low Level Adjustable Terminal to the wall is adhered to - (See FIG 8.0) before locking in place using the provided locking band.

Assemble the rest of the plume kit as required ensuring all locking bands are tightened, wall brackets are fitted/secured and that the termination of the plume terminal is in accordance with BS5410 part 1 or part 2.



IMPORTANT - If Plume Extension Sections are used (ie the 250mm, 500mm or 950mm sections) in addition to the 1000/2000mm adjustable section. It is **IMPORTANT** that the 1000/2000mm adjustable section is fitted at the end of the plume installation as the adjustable section is classed as **NON-LOAD BEARING**. If additional sections were to be added after the end of this adjustable section, the extra weight may cause the adjustable section to shorten over time (see FIGS 8.1 & 8.2) EOGBs Plume Kit options allows for plume runs to be extended by using additional extension sections and offset 45° elbows to give much more flexibility when fitting a plume kit.

A maximum total height of 6 metres' is allowed. However, please deduct 500mm for each additional 45° elbow used.

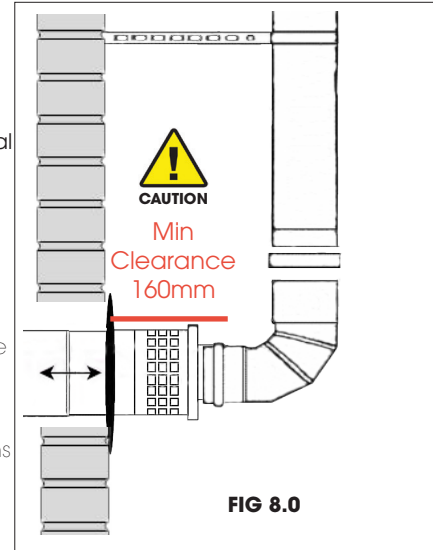

FIG 8.0

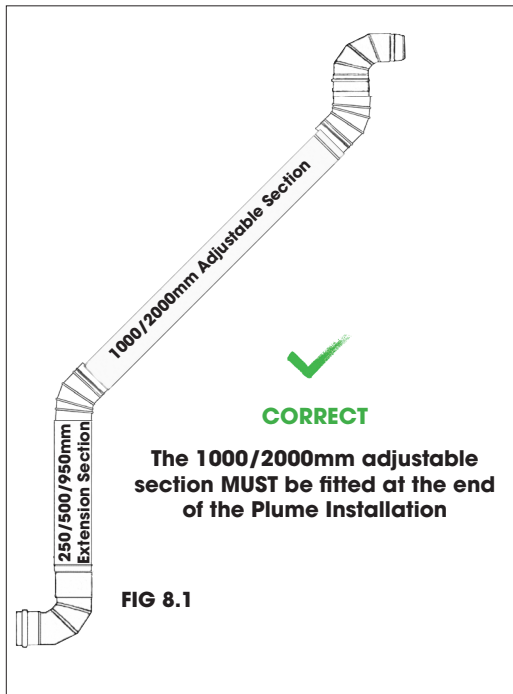

FIG 8.1

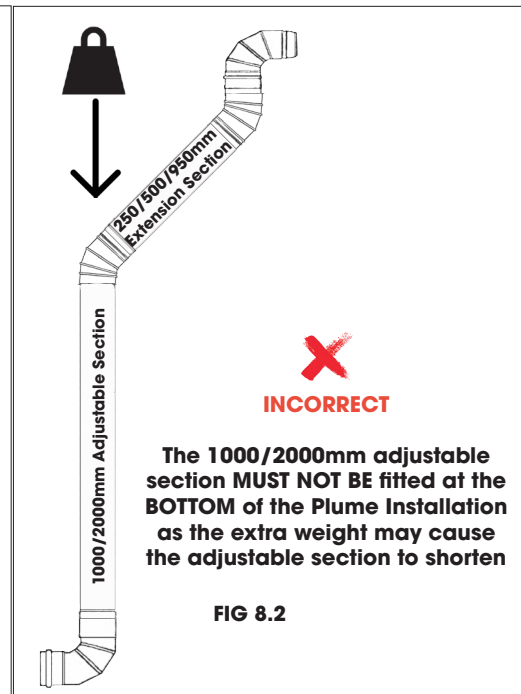
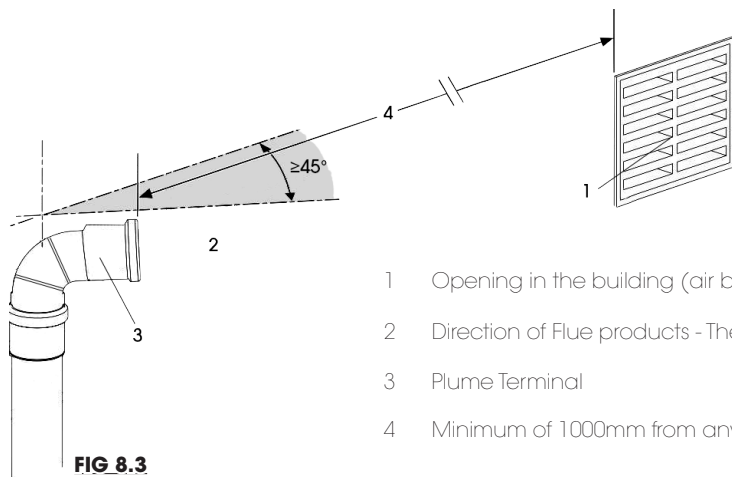

FIG 8.2

When positioning the direction of the plume terminal, ensure that the minimum dimensions and angles from any openings in the building (Air brick, Vents, Windows etc), are adhered to - See Fig 8.3)



- 1 Opening in the building (air brick, window)
- 2 Direction of Flue products - The angle must be equal or more than 45° from the wall/structure.
- 3 Plume Terminal
- 4 Minimum of 1000mm from any opening in the building

FIG 8.3

PLUME KIT Options (Low Level)

3.2 Plume Kit Part Numbers

Item	Description	Part number
	HORIZONTAL Plume Stater Kit 1 x 90° Terminal 1 x 90° Plume Adapter 2 x Wall Brackets Locking bands	Stainless Steel - SS-FLUEKITPLH-SS-01 Black Finish - SS-FLUEKITPLH-BK-01
	90° Plume Terminal c/w locking bands	Stainless Steel - SS-FLUE101-SS-03 Black Finish - SS-FLUE101-BK-03
	Plume Adjustable c/w locking bands 1000-2000mm	Stainless Steel - SS-FLUE110-SS-01 Black Finish - SS-FLUE110-BK-01
	Plume Extension c/w locking bands 950mm	Stainless Steel - SS-FLUE105-SS-01 Black Finish - SS-FLUE105-BK-01
	Plume Extension c/w locking bands 500mm	Stainless Steel - SS-FLUE107-SS-01 Black Finish - SS-FLUE107-BK-01
	Plume Extension c/w locking bands 250mm	Stainless Steel - SS-FLUE108-SS-01 Black Finish - SS-FLUE108-BK-01
	Plume Wall Bracket (80-300mm)	Stainless Steel - SS-FLUE109-SS-01 Black Finish - SS-FLUE109-BK-01
	Plume 90° Terminal Adaptor	Stainless Steel - SS-FLUE103-SS-01 Black Finish - SS-FLUE103-BK-01
	45° Plume Elbow c/w locking bands	Stainless Steel - SS-FLUE104-SS-01 Black Finish - SS-FLUE104-BK-01
	Inner 80mm Flue Seal (Red)	SS-FLUE111-OT-01
	Locking Band SW 80mm (standard extension type)	Stainless Steel - SS-FLUE112-SS-01 Black Finish - SS-FLUE112-BK-01
	Locking Band SW 80mm (adjustable extension type)	Stainless Steel - SS-FLUE113-SS-01 Black Finish - SS-FLUE113-BK-01
	Noise reducing Plume Cone Kit (incs 4 x screws)	SS-ACCESS-028-01

Table 3.0

High Level Balanced Flue Options (Internal)

4.0 EOGB Sapphire High Level Stainless Steel Balanced Flue System Kits

The EOGB Sapphire high level type balanced flues have been developed to make the installation of the Sapphire Boilers both quick and simple.

The Sapphire high level flue kits feature self-sealing ducts requiring no silicone or tape for joints, and the unique quick-fit connection arrangement ensures a perfect seal every time. The kits are compatible with all Sapphire boilers and available with Terminals in either a black painted finish or stainless steel (which can be painted after installation) Please note that any internal vertical/horizontal sections are only available in a stainless steel finish but can be painted if required.



Both terminals options are available in both **Short** and **Long** versions

IMPORTANT - Please note that EOGB High Level Terminals are NOT compatible with Low Level Terminals and vice versa

4.1 High Level Stainless Steel Balanced Flue System Kit Configurations & Dimensions

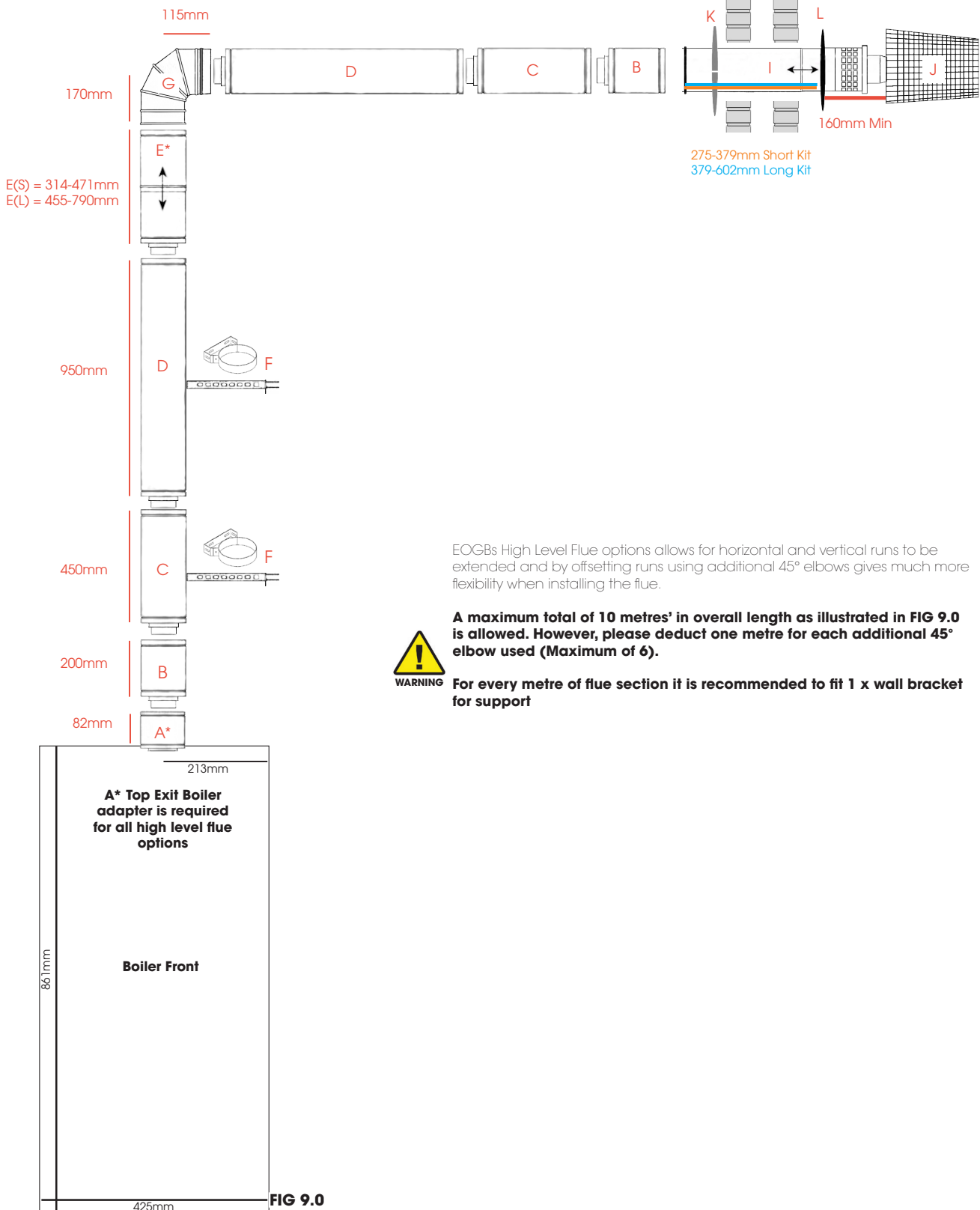
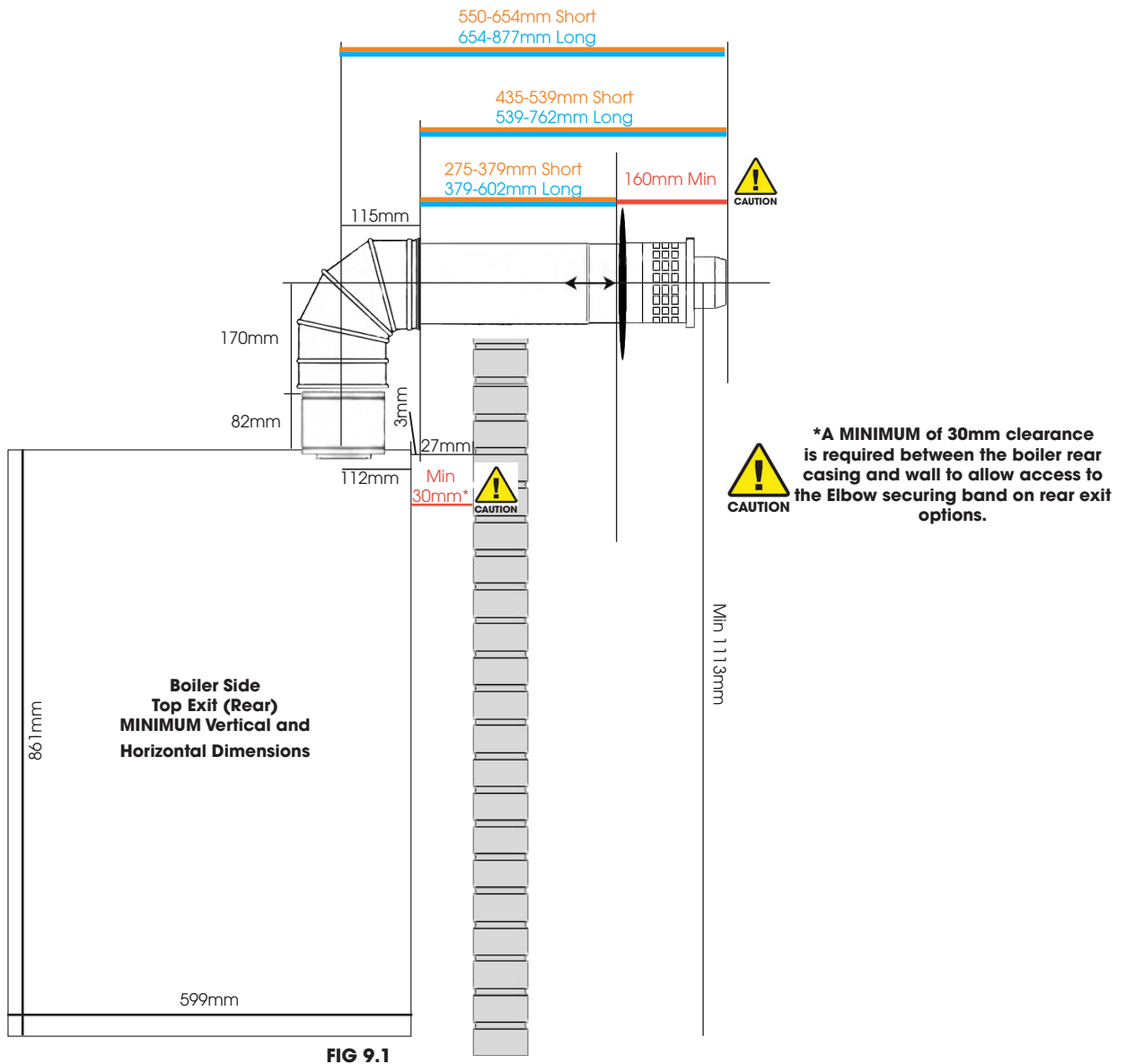

FIG 9.0

High Level Balanced Flue Options (Internal)

4.2 High Level Type Short & Long Kit (Rear Exit) Dimensions



4.3 MINIMUM CLEARANCES AND PROJECTIONS for High level Type Terminals (Rear)

Short and Long Adjustable Standard High Level Terminal Minimum Clearances

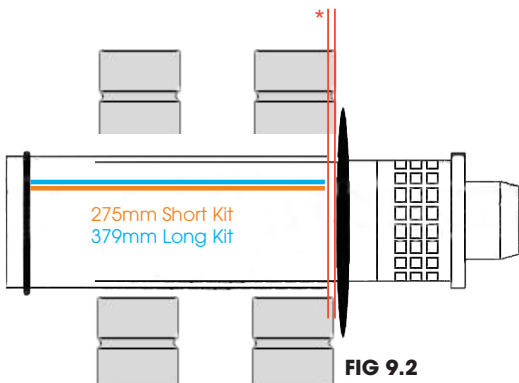

Short and Long Adjustable Standard High Level Minimum/Maximum Terminal Projection

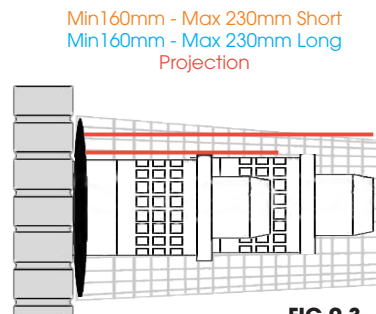

* The fixed section of the terminal **MUST** be located within the wall cavity to prevent rain water from entering and allowing the external flashing to seal

High Level Balanced Flue Options (Internal)

4.4 High Level Type Short & Long Kit (SIDE Exit) Dimensions

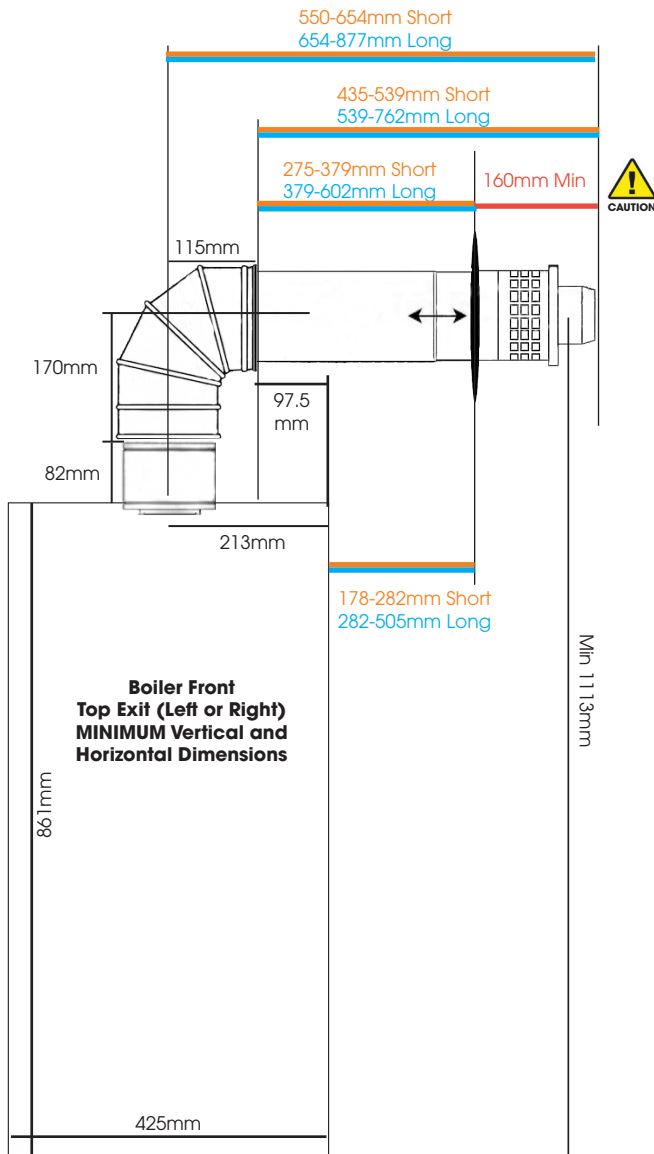
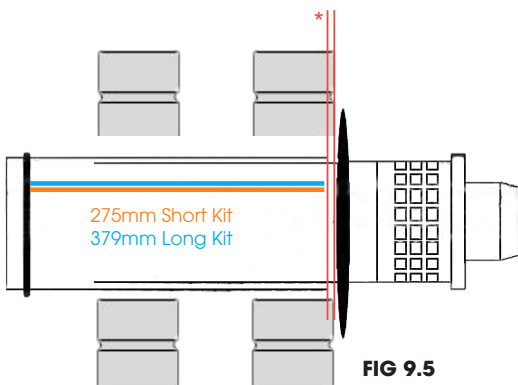

FIG 9.4

4.5 MINIMUM CLEARANCES AND PROJECTIONS for High level Type Terminals (Side)

Short and Long Adjustable Standard High Level Terminal Minimum Clearances



Short and Long Adjustable Standard High Level Minimum/Maximum Terminal Projection

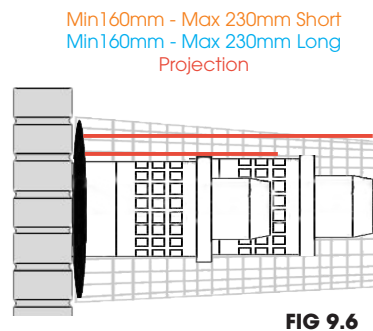

* The fixed section of the terminal **MUST** be located within the wall cavity to prevent rain water from entering and allowing the external flashing to seal

High Level Balanced Flue Options (Internal)

4.6 High Level Offset Flue Options/Dimensions

Should you require to offset a section of vertical flue, Please see dimensions in **Fig 9.7 / 9.8 & Table 4.0**

4.0

Please note that it is highly recommended to keep bends to a minimum

A maximum total of 10 metres' in overall length as illustrated in section 4.1 is allowed. However, please deduct one metre for each additional 45° elbow used (Maximum of 6).

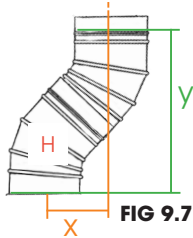

x = 127mm
y = 306mm

Section (all in mm)						
	B	C	D	E(S)		E(L)
	200	450	950	314	471	455 795
X	268	445	798	349	460	448 689
Y	447	624	977	528	639	627 868

Table 4.0

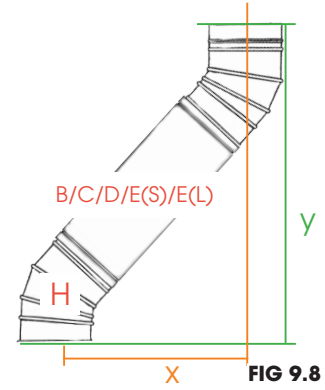

4.7 Top Exit Boiler Adaptor

For any High level or Vertical Installation The **Top Exit Boiler Adaptor** **MUST** be used. Please ensure that the boiler casing knock out on the top of the boiler has been removed and the **Boiler Air intake Adaptor** (supplied with the boiler) has been fitted in the correct orientation (please refer to the Sapphire Boiler Installation Manual for more information.)

Then simply push in the **Top Exit Boiler Adaptor** (ensuring that all seals are lubricated with lubrication supplied) into the **Boiler Air intake Adaptor**.

4.8 Drilling the High Level Flue Termination Hole

Ensure the correct measurements for the flue terminal exit hole have been measured (see **Table 5.0**) and are in accordance with BS5410 Part 1 or 2 and Approved Document J

Drill out using a core cutter or other suitable cutting tool, the correct flue terminal hole size (See **Table 5.0**).

Once the flue terminal exit hole has been made, ensure that the hole and the cavity are free of any debris or potential falling debris.

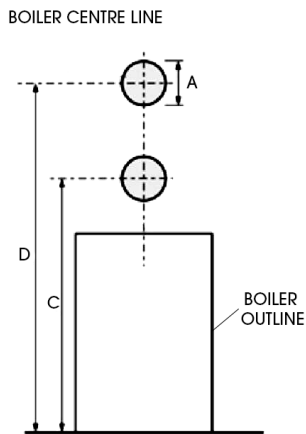

FIG 10.0

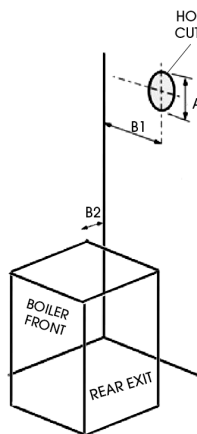

FIG 10.1

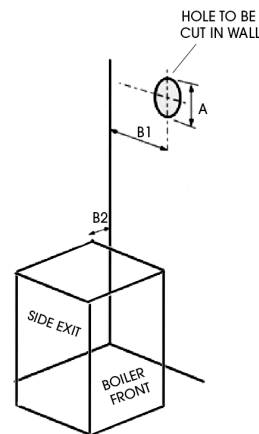

FIG 10.2

High level side and rear exit balanced flue dimensions							
Boiler Model (Kw)	Dimensions (mm)						
	A (dia)	Rear Exit		Side Exit		Rear & Side Exit	
		B1	B2*	B1	B2	C min	D
Sapphire 6-32	127mm	213mm	30mm Min	112mm	0mm Min	1113mm	Sections A & G + any length of additional sections used (ie Sections B, C, D, E(S) or E(L) (see Fig 9.0)

TABLE 5.0



* **IMPORTANT** - For High level **REAR** exit flue options, **PLEASE ENSURE** that the **MINIMUM 30mm CLEARANCE** between boiler and rear wall is adhered too. Please see section 4.2 Fig 9.1 for more information

High Level Balanced Flue Options (Internal)

4.9 Fitting the High Level Flue Terminal

Starting at the boiler end, assemble any vertical sections into the Top Exit Boiler Adaptor (ensuring that all seals are lubricated with lubrication supplied).



NOTE - If an **Adjustable Vertical Section** is fitted on the vertical section, please ensure that it is **fitted at the top**. This is to ensure that no excessive weight is being placed on the **Vertical Section** which could cause it to shorten (See FIG 11.0 & 11.1)

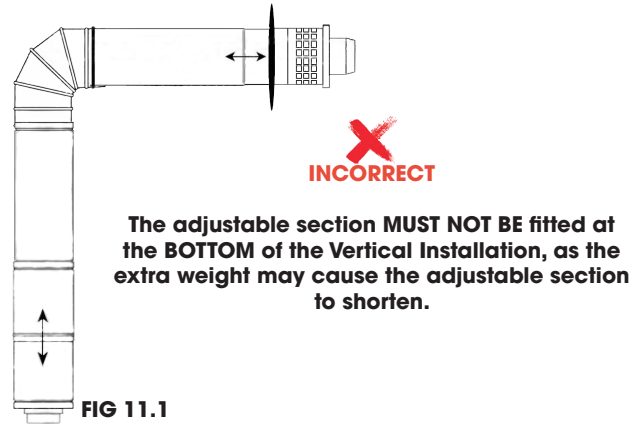
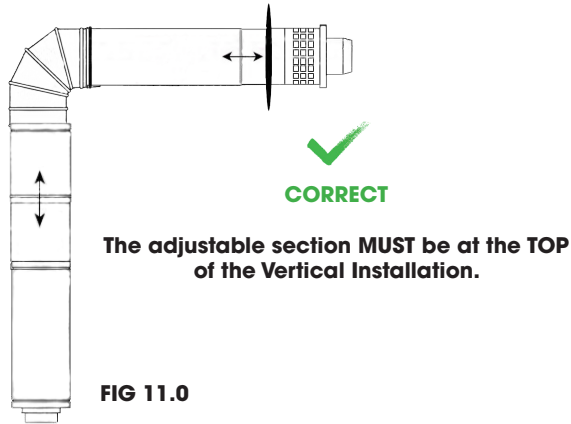

Carefully install any 90° or 45° Bends and Horizontal Extension sections (if used) and connect to the High Level Adjustable (Short or Long) Terminal (ensure that any flue seals have been lubricated using the lubrication sachets provided) and Insert the High Level Adjustable Terminal through the flue terminal exit hole in the wall



Once the terminal is in place, adjust the adjustable terminal to the desired length ensuring that the minimum terminal projections are adhered to (see section **MINIMUM CLEARANCES AND PROJECTIONS** for Short and Long Adjustable High Level **STANDARD** Terminals (Side and Rear)*) In **Section 4.2** - **Then check and ensure all locking bands are tight.**

Once set, ensure that the internal and external wall flashing plates are fitted and sufficient support brackets are in place. It is recommend that for every 1 metre of flue that 1 support bracket is fitted.

If required, fit the Terminal Cage Guard.

4.10 Short and Long Adjustable High Level Kits & Part Numbers

Item	Description	Part number
	High Level Top Exit SHORT Terminal Starter Kit 1 x Top Exit Boiler Adaptor 1 x 90° Elbow Flue 1 x Adjustable SHORT Terminal Section (275-379mm) 1 x Internal & External Flashing plates 1 x Support Bracket (60mm) 1 x Support Bracket extension (60-300mm) 1 x Terminal Cage Guard (C/W Locking Bands)	Stainless Steel Terminal- SS-FLUEKITHLS-SS-01 Stainless Steel with Black Terminal- SS-FLUEKITHLS-BK-01
	High Level Top Exit LONG Terminal Starter Kit 1 x Top Exit Boiler Adaptor 1 x 90° Elbow Flue 1 x Adjustable LONG Terminal Section (379-602mm) 1 x Internal & External Flashing plates 1 x Support Bracket (60mm) 1 x Support Bracket extension (60-300mm) 1 x Terminal Cage Guard (C/W Locking Bands)	Stainless Steel Terminal- SS-FLUEKITHLL-SS-01 Stainless Steel with Black Terminal- SS-FLUEKITHLL-BK-01
	1 x Adjustable SHORT Terminal Section (275-379mm) 1 x Internal & External Flashing plates 1 x Terminal Cage Guard	Stainless Steel Terminal- SS-FLUE201-SS-01 Stainless Steel with Black Terminal- SS-FLUE201-BK-01
	1 x Adjustable LONG Terminal Section (379-602mm) 1 x Internal & External Flashing plates 1 x Terminal Cage Guard	Stainless Steel Terminal- SS-FLUE202-SS-01 Stainless Steel with Black Terminal- SS-FLUE202-BK-01

TABLE 6.0

High Level Balanced Flue Options (Internal)

Item	Description	Part number
	Adjustable Vertical Extension 314-471mm (C/W Locking Band)	Stainless Steel Only- SS-FLUE205-SS-01
	Adjustable Vertical Extension 455-795mm (C/W Locking Band)	Stainless Steel Only- SS-FLUE206-SS-01
	Extension 950mm (C/W Locking Band)	Stainless Steel Only- SS-FLUE207-SS-01
	Extension 450mm (C/W Locking Band)	Stainless Steel Only- SS-FLUE208-SS-01
	Extension 200mm (C/W Locking Band)	Stainless Steel Only- SS-FLUE209-SS-01
	90° Elbow Kit (C/W Locking Band)	Stainless Steel Only- SS-FLUE210-SS-01
	45° Elbow kit (C/W Locking Band)	Stainless Steel Only- SS-FLUE211-SS-01
	Support Bracket (60mm)	Stainless Steel Only- SS-FLUE212-SS-01
	Support Bracket extension (60-300mm)	Stainless Steel Only- SS-FLUE213-SS-01
	Terminal Cage Guard	Stainless Steel Only- SS-FLUE214-SS-01
	Top Exit Boiler Adaptor (82mm) (MUST be fitted on all High level/Vertical Flues)	Stainless Steel Only- SS-FLUE204-SS-01
	Internal Flashing Plate	Stainless Steel Only- SS-FLUE218-SS-01
	External Flashing Plate	Stainless Steel Only- SS-FLUE220-SS-01 Black - SS-FLUE-219-BK-01
	Inner 80mm flue seal (Red)	SS-FLUE111-OT-01
	Outer 120mm flue seal (Black)	SS-FLUE221-OT-01
	Locking band TW 125mm (standard extension type)	SS-FLUE222-SS-01
	Locking band TW 125mm (adjustable extension type)	SS-FLUE223-SS-01
	Top Exit Boiler Adaptor Test Point Sealing Bolt/Washer Kit	SS-FLUE001-OT-01
	LL/HL Flue noise reducing cone kit (incs 4 x screws)	SS-ACCESS-023-01

TABLE 6.0

Vertical Balanced Flue Options (Internal)

5.0 EOGB Sapphire Vertical Stainless Steel Balanced Flue System Kits & Dimensions

The EOGB Sapphire vertical type balanced flues have been developed to make the installation of the Sapphire Boilers both quick and simple.

The Sapphire vertical flue kits feature self-sealing ducts requiring no silicone or tape for joints, and the unique quick-fit connection arrangement ensures a perfect seal every time. The kits are compatible with all Sapphire boilers and comes as a stainless steel finish which can be painted after installation.

The design reduces the possibility of condensate, produced in the combustion process, staining external wall surfaces or patio slabs

Terminal options are available in both **Flat** and **Pitched Roof** versions and include both flashing, storm seal collar and silicon.

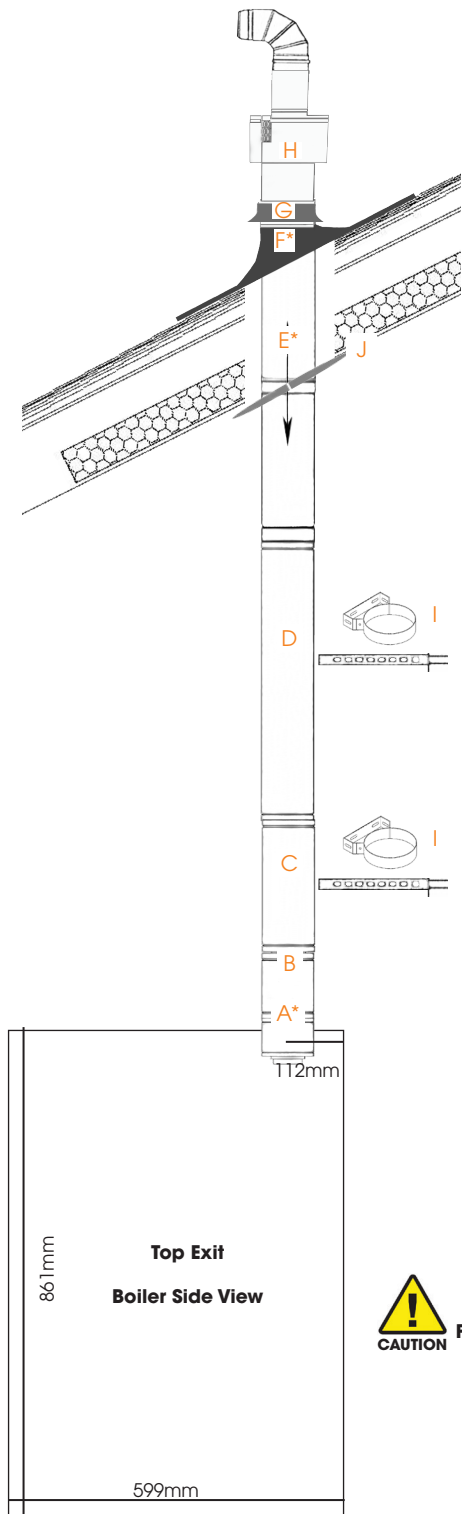

FIG 12.0

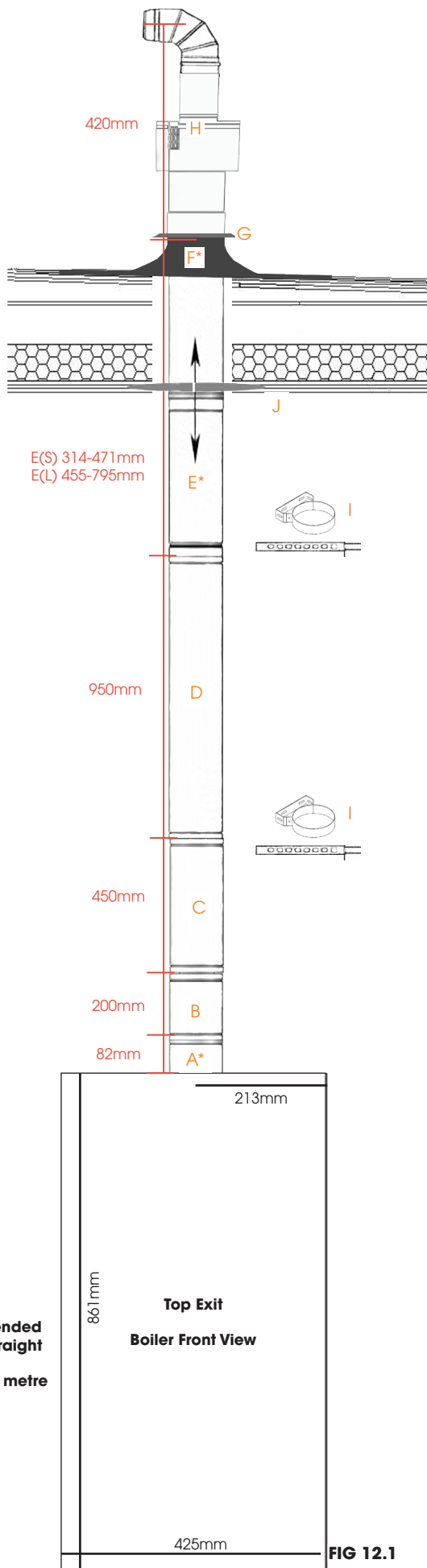

FIG 12.1

A* Top Exit Boiler adapter is required for all vertical flue options

CAUTION EOGB Vertical balanced flues can be extended to a maximum length of 12 metres' in a straight run. For every 45° elbow used, please deduct 1 metre (maximum 6 elbows)

Vertical Balanced Flue Options (Internal)

5.1 Vertical Offset Flue Options/Dimensions

Should you require to offset a section of vertical flue, Please see dimensions in **Fig 12.2 / 12.3 & Table 7.0**

Please note that it is highly recommended to keep bends to a minimum



A maximum total of 12 metres' in overall length as illustrated in Fig 12.0 & 12.1 is allowed. However, please deduct one metre for each additional 45° elbow used (Maximum of 6).

x = 127mm
y = 306mm

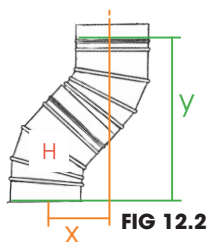

FIG 12.2

Section (all in mm)						
	B	C	D	E(S)	E(L)	
	200	450	950	314	471	795
X	268	445	798	349	460	689
Y	447	624	977	528	639	868

Table 7.0

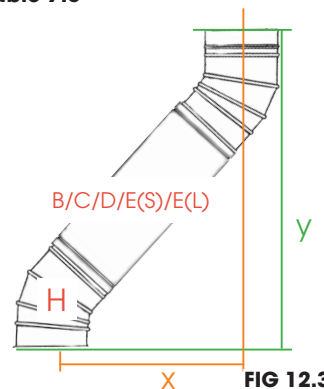

FIG 12.3

5.2 Drilling the Flue Termination Hole

Ensure the correct measurements for the flue terminal exit hole have been measured (127mm Minimum) and are in accordance with BS5410 Part 1 or 2 and Approved Document J

Once the flue terminal exit hole has been made, ensure that the hole and the cavity are free of any debris or potential falling debris.

5.3 Top Exit Boiler Adaptor



For any High level or Vertical Installation The Top Exit Boiler Adaptor **MUST** be used. Please ensure that the boiler casing knock out on the top of the boiler has been removed and the Boiler Air intake Adaptor (supplied with the boiler) has been fitted in the correct orientation (please refer to the Sapphire Boiler Installation Manual for more information.)

Then simply push in the Top Exit Boiler Adaptor (ensuring that all seals are lubricated with lubrication supplied) into the Boiler Air intake Adaptor (please refer to the Sapphire Boiler Installation Manual for more information.)

5.4 Fitting the Vertical Flue Terminal

Starting at the boiler end, assemble any vertical sections into the Top Exit Boiler Adaptor (ensuring that all seals are lubricated with lubrication supplied).

NOTE - If an Adjustable Vertical Section is fitted on the vertical section, please ensure that it is fitted at the top. This is to ensure that no excessive weight is being placed on the Vertical Section which could cause it to shorten (See FIG 12.4 & 12.5)

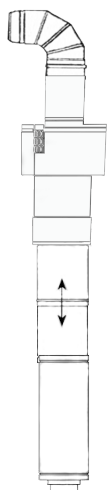

FIG 12.4

✓
CORRECT

The adjustable section **MUST** be at the **TOP** of the Vertical Installation

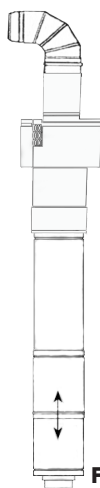

FIG 12.5

✗
INCORRECT

The adjustable section **MUST NOT BE** fitted at the **BOTTOM** of the Vertical Installation, as the extra weight may cause the adjustable section to shorten.

Carefully install any 45° Offset Bends (if used) and then pass the Vertical Extension Section through the terminal hole in the roof.

Place either the Flat or Pitched Roof Flashing over the Vertical Extension Section ensuring the minimum height is in accordance with BS5410 Part 1 or 2 and Approved Document J.

Then place the Vertical Terminal onto the Vertical Extension Section and **check and ensure or locking bands are tight and Support Brackets are fitted** (It is recommend that for every 1 metre of flue that 1 support bracket is fitted.)

To Finish, Fit the Storm collar and Silicon seal around edge (see FIG 12.6) to weatherproof and ensure that the Flashing has been sealed/weatherproofed sufficiently

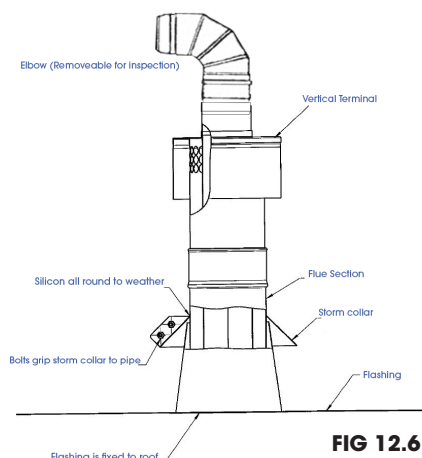

FIG 12.6

Vertical Balanced Flue Options (Internal)

5.5 Vertical Balanced Flue Kits & Part Numbers

Item	Description	Part number
	<p>FLAT ROOF VERTICAL Flue Kit</p> <p>1 x Vertical Terminal with Elbow 1 x Flat roof flashing (incs Storm Collar) 1 x Top Exit Boiler Adaptor 2 x Support Bracket (60mm) 2 x Support Bracket extension (60-300mm) 1 x Internal Flashing Plate 1 x Tube of Silicon</p>	<p>Stainless Steel - SS-FLUEKITVFK-SS-02</p>
	<p>PITCHED ROOF VERTICAL Flue Kit</p> <p>1 x Vertical Terminal with Elbow 1 x Pitched roof flashing (incs Storm Collar) 1 x Top Exit Boiler Adaptor 2 x Support Bracket (60mm) 2 x Support Bracket extension (60-300mm) 1 x Internal Flashing Plate 1 x Tube of Silicon</p>	<p>Stainless Steel - SS-FLUEKITVPK-SS-02</p>
	<p>Vertical Terminal and Elbow Only</p>	<p>Stainless Steel - SS-FLUE203-SS-02</p>
	<p>FLAT Roof Flashing Kits (incs Storm Collar and Silicon)</p>	<p>SS-FLUE215-OT-01</p>
	<p>PITCHED Roof Flashing Kits (incs Storm Collar and Silicon)</p>	<p>SS-FLUE216-OT-01</p>
	<p>Storm Collar (Separate)</p>	<p>Flat Roof - SS-FLUE217-OT-01 Pitched Roof - SS-FLUE224-OT-01</p>
	<p>Adjustable Vertical Extension 314-471mm (C/W Locking Band)</p>	<p>Stainless Steel Only- SS-FLUE205-SS-01</p>
	<p>Adjustable Vertical Extension 455-795mm (C/W Locking Band)</p>	<p>Stainless Steel Only- SS-FLUE204-SS-01</p>
	<p>Extension 950mm (C/W Locking Band)</p>	<p>Stainless Steel Only- SS-FLUE207-SS-01</p>
	<p>Extension 450mm (C/W Locking Band)</p>	<p>Stainless Steel Only- SS-FLUE208-SS-01</p>
	<p>Extension 200mm (C/W Locking Band)</p>	<p>Stainless Steel Only- SS-FLUE209-SS-01</p>
	<p>45° Elbow only (C/W Locking Band)</p>	<p>Stainless Steel Only- SS-FLUE211-SS-01</p>
	<p>Support Bracket (60mm)</p>	<p>Stainless Steel Only- SS-FLUE212-SS-01</p>
	<p>Support Bracket extension (60-300mm)</p>	<p>Stainless Steel Only- SS-FLUE213-SS-01</p>

Vertical Balanced Flue Options (Internal)

Item	Description	Part number
 	Top Exit Boiler Adaptor (MUST be fitted on all High level/Vertical Flues)	Stainless Steel Only- SS-FLUE204-SS-01
	Internal Flashing Plate	Stainless Steel Only- SS-FLUE218-SS-01
	Inner 80mm flue seal (Red)	SS-FLUE111-OT-01
	Outer 120mm flue seal (Black)	SS-FLUE221-OT-01
	Locking band TW 125mm (standard extension type)	SS-FLUE222-SS-01
	Locking band TW 125mm (adjustable extension type)	SS-FLUE223-SS-01
	Top Exit Boiler Adaptor Test Point Sealing Bolt/Washer Kit	SS-FLUE001-OT-01
	LL/HL Flue noise reducing cone kit (incs 4 x screws)	SS-ACCESS-023-01

TABLE 8.0

5.6 Noise Reducing Flue Cone

EOGB now fit a flue noise reducing cone to the end of all flue terminals including Plume kits. This noise reducing cone helps dampen the noises caused through the combustion process. The cone is secured by 4 fixing screws and can be retrofitted.



6.0 Balanced Flue Terminal Location Installation Guidance

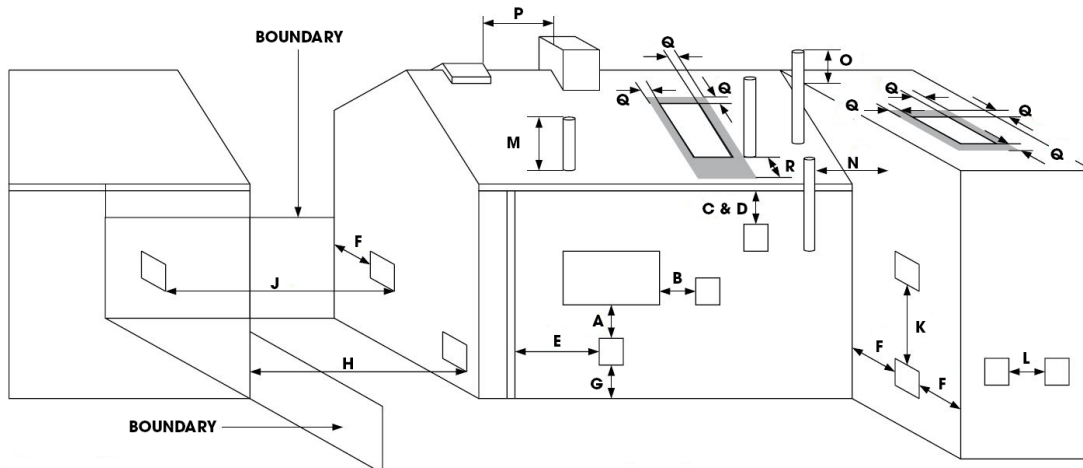

	Location	Appliance Burner Type
		Pressure Jet
		Condensing
A	Directly below an opening, air brick, opening window etc.	1000mm*
B	Horizontally to an opening, air brick, opening window etc.	1000mm*
C	Below a gutter, eaves or balcony with protection	1000mm*
D	Below a gutter or a balcony without protection	1000mm*
E	From vertical sanitary pipe work	300mm
F	From an internal or external corner or surface or boundary alongside the terminal	300mm
G	Above ground or balcony level	300mm
H	From a surface or a boundary facing the terminal	2500mm*
J	From a terminal facing the terminal	1200mm
K	Vertically from a terminal on the same wall	1500mm
L	Horizontally from a terminal on the same wall	750mm
M	Above the highest point of an intersection with a roof	600mm
N	From a vertical structure on the side of the terminal	750mm
O	Above a vertical structure less than 750mm from the side of the terminal	600mm
P	From a ridge terminal to a vertical structure on the roof	1500mm
Q	Above or to the side of any opening on a flat or sloping roof	300mm**
R	Below any opening on a sloping roof	1000mm**

* Recommended clearances to alleviate the effect of plume nuisance. For further guidance please see **OFTEC Book 4**

** More onerous requirements apply in England, Guernsey, Isle of Man, Jersey, Scotland and Wales. Please check the applicable regional requirements in **OFTEC Book 4**

Important Notes

- Terminals should be positioned to avoid products of combustion accumulating in stagnant pockets around the building, or entering into buildings
- Appliances burning class D are not permitted on the EOGB Sapphire Appliances
- Vertical structure in N, O and P includes tank or lift rooms, parapets, dormers, etc.
- Terminating positions A to L are only permitted for appliances that have been approved for low level flue discharge when tested in accordance with BS EN 303-1
- Terminating positions should be at least 1.8 metres from an oil storage tank unless a wall with at least 30 minutes fire resistance and extending 300 mm higher and wider than the tank is provided between the tank and the terminating position.
- Where a flue is terminated less than 600 mm away from a projection above it and the projection consists of plastics or has a combustible or painted surface, then a heat shield of at least 750 mm wide should be fitted to protect these surfaces.
- If the lowest part of the terminal is less than 2 metres above the ground, balcony, flat roof or other place to which any person has access, the terminal should be protected by a guard.
- Notwithstanding the dimensions given above, a terminal should not be sited closer than 300 mm to combustible material. In the case of a thatched roof, double this separation distance should be provided. It is also advisable to treat the thatch with a fire retardant material and close wire in the immediate vicinity of the flue.
- A flue or chimney should not pass through the roof within the shaded area delineated by dimensions Q and R.
- Where protection is provided for plastics components, such as guttering, this should be to the standard specified by the manufacturer of the plastics components.
- Terminals must not be sited under car ports.
- Terminals at low levels (terminals under 2.1 metres) have more restrictive recommendations and should not be positioned near public foot ways, frequently used access routes, car parking spaces less than 2.5 metres from the terminal or patio's (hard surface area).

Further guidance can be obtained from BS 5410-1:2019, OFTEC Book 4 (Installation) and Approved Document J



EOGB Energy Products Ltd, 5 Howard Road, Eaton Socon, St Neots, Cambridgeshire PE19 8ET

Tel: 01480 477066 Fax: 01480 477022 Email: sales@sapphireboilers.co.uk

www.sapphireboilers.co.uk



www.youtube.com/EOGBenergyproducts



@EOGBburners

